



Designation: D4506 – 21

Standard Test Method for Determining In Situ Modulus of Deformation of a Rock Mass Using the Radial Jacking Test¹

This standard is issued under the fixed designation D4506; the number immediately following the designation indicates the year of original adoption or, in the case of revision, the year of last revision. A number in parentheses indicates the year of last reapproval. A superscript epsilon (ϵ) indicates an editorial change since the last revision or reapproval.

1. Scope*

1.1 This test method is used to determine the in situ modulus of deformation of rock mass by subjecting a test chamber in rock of a circular cross-section to uniformly distributed radial loading; the consequent rock radial displacements are measured at various locations, from which the deformation modulus may be calculated. The radial anisotropic deformability of the rock is taken at enough locations that it can also be determined from the differences between the extensometer readings taken at various locations along and around the test chamber as well with depth from each loading sequence. Information on time-dependent deformation may be obtained as well by holding the loads constant for selected time intervals.

NOTE 1—Deformations caused by a cylindrical test chamber are not likely uniform even if each steel ring forming the jack is uniformly loaded. Theoretically, the deformations will vary along the cylinder such that it looks like a gaussian probability curve.

1.2 This test method is based upon the procedures developed by the US Bureau of Reclamation, featuring long extensometers that provide a bottom anchor far enough away from the test zone to be used as a zero reference point (Fig. 1)(1).² An alternative procedure, the New Austrian method, is also available and is based on a reference bar going down the middle to support posts outside the deflection zone due to the testing loads and shown in Fig. 2(2). Other than a different method of taking deformation readings, the two field tests are the same. Additional information on radial jacking and data analysis is presented in References (3-8).

1.3 Application of the test results is beyond the scope of this test method, but may be an integral part of some testing programs. (See Note 2.)

NOTE 2—For example, in situ stresses around the test tunnel will affect the test results, depending on how the test results will be used and may

¹ This test method is under the jurisdiction of ASTM Committee D18 on Soil and Rock and is the direct responsibility of Subcommittee D18.12 on Rock Mechanics.

Current edition approved Sept. 1, 2021. Published October 2021. Originally approved in 1985. Last previous edition approved in 2013 as D4506 – 13^{ε1}. DOI: 10.1520/D4506-21.

² The boldface numbers in parentheses refer to the list of references appended to this standard.

need to be considered in any analyzes or recommendations.

1.4 Testing of the in situ rock deformation behavior is limited by the maximum stress range of the reaction frame and the flat jacks.

1.5 *Units*—The values stated in inch-pound units are to be regarded as standard. The values given in parentheses are rationalized mathematical conversions to SI units that are provided for information only and are not considered standard. Reporting of test results in units other than inch-pound shall not be regarded as nonconformance with this test method.

1.5.1 The SI units presented for apparatus are substitutions of the inch-pound units, other similar SI units should be acceptable, providing they meet the technical requirements established by the inch-pound apparatus.

1.5.2 The gravitational system of inch-pound units is used when dealing with inch-pound units. In this system, the pound (lbf) represents a unit of force (weight), while the unit for mass is slugs. The slug unit is not given unless dynamic ($F=ma$) calculations are involved.

1.5.3 The slug unit of mass is typically not used in commercial practice; that is, density, balances, and so on. Therefore, the standard unit for mass in this standard is either kilogram (kg) or gram (g) or both. Also, the equivalent inch-pound unit (slug) is not given/presented in parenthesis.

1.5.4 It is common practice in the engineering/construction profession to concurrently use pounds to represent both a unit of mass (lbm) and of force (lbf). This practice implicitly combines two separate systems of units; the absolute and the gravitational systems. It is scientifically undesirable to combine the use of two separate sets of inch-pound units within a single standard. As stated, this standard includes the gravitational system of inch-pound units and does not use/present the slug unit for mass. However, the use of balances or scales recording pounds of mass (lbm) or recording density in lbm/ft³ shall not be regarded as nonconformance with this standard.

1.5.5 Calculations are done using only one set of units; either SI or gravitational inch-pound. Other units are permissible, provided appropriate conversion factors are used to maintain consistency of units throughout the calculations, and similar significant digits or resolution, or both are maintained.

*A Summary of Changes section appears at the end of this standard

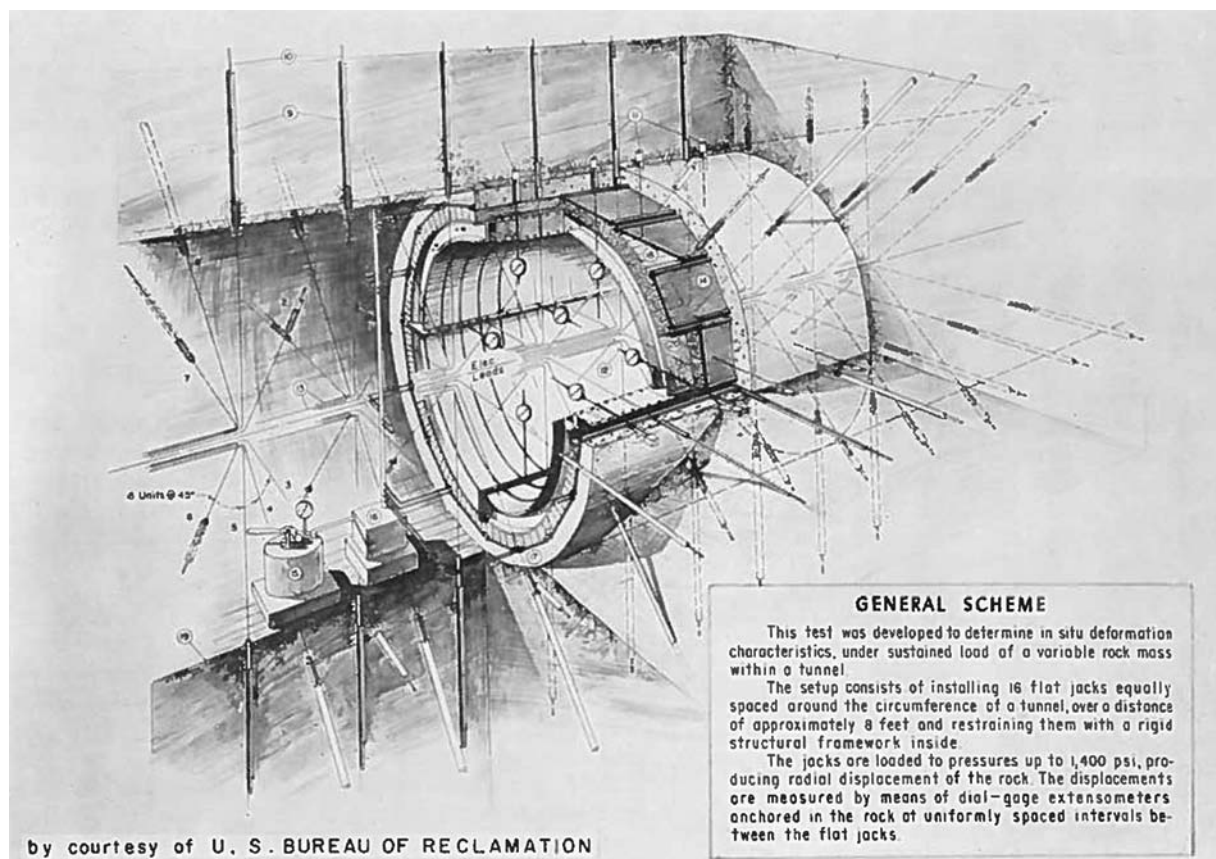

FIG. 1 General Diagram and Scheme of a Radial Jacking Test Setup used by the US Bureau of Reclamation (1, 9)

1.6 All observed and calculated values shall conform to the guidelines for significant digits and rounding established in Practice D6026, unless superseded by this standard.

1.6.1 For purposes of comparing measured or calculated value(s) with specified limits, the measured or calculated value(s) shall be rounded to the nearest decimal or significant digits in the specified limits.

1.6.2 The procedures used to specify how data are collected/recorded or calculated in this standard are regarded as the industry standard. In addition, they are representative of the significant digits that generally should be retained. The procedures used do not consider material variation, the purpose for obtaining the data, special purpose studies, or any considerations for the user's objectives; and it is common practice to increase or reduce significant digits of reported data to be commensurate with these considerations. It is beyond the scope of this standard to consider significant digits used in analytical methods for engineering design.

NOTE 3—The discussion about significant digits and rounding in 1.6 above and within the standard sections that follow about significant digits, rounding, accuracy, and the number of readings is geared more toward manual type readings. However, even with any electronic data acquisition system, the readings should still be taken equal to or better than with any manual data acquisition requirements.

1.7 This standard does not purport to address all of the safety concerns, if any, associated with its use. It is the responsibility of the user of this standard to establish appropriate

safety, health, and environmental practices and determine the applicability of regulatory limitations prior to use.

1.8 This international standard was developed in accordance with internationally recognized principles on standardization established in the Decision on Principles for the Development of International Standards, Guides and Recommendations issued by the World Trade Organization Technical Barriers to Trade (TBT) Committee.

2. Referenced Documents

2.1 ASTM Standards:³

C31/C31M Practice for Making and Curing Concrete Test Specimens in the Field

D420 Guide for Site Characterization for Engineering Design and Construction Purposes

D653 Terminology Relating to Soil, Rock, and Contained Fluids

D3740 Practice for Minimum Requirements for Agencies Engaged in Testing and/or Inspection of Soil and Rock as Used in Engineering Design and Construction

D4403 Practice for Extensometers Used in Rock

³ For referenced ASTM standards, visit the ASTM website, www.astm.org, or contact ASTM Customer Service at service@astm.org. For Annual Book of ASTM Standards volume information, refer to the standard's Document Summary page on the ASTM website.

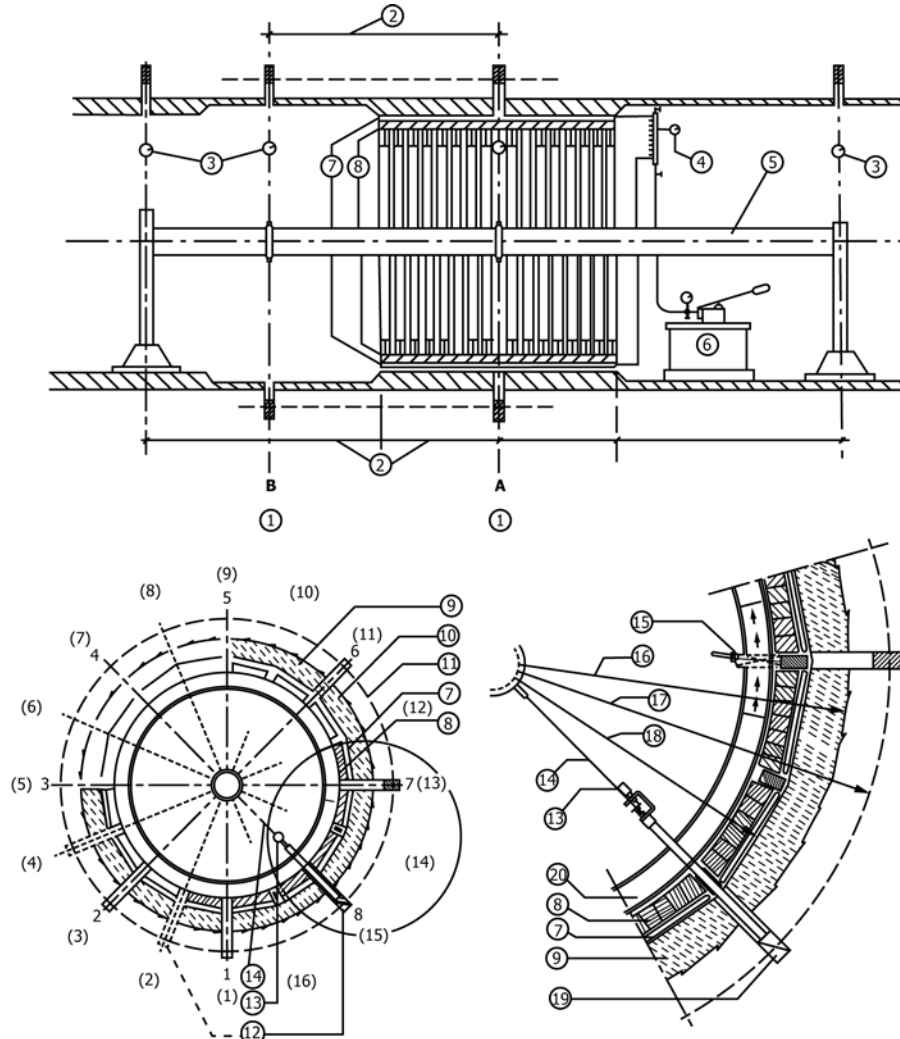

Circled numbers: 1. Measuring profile. 2. Distance equal to the length of active loading. 3. Control extensometer. 4. Pressure gauge. 5. Reference beam. 6. Hydraulic pump. 7. Flat jack. 8. Wood spacer for reaction frame curvature compensation. 9. Concrete. 10. Excavation diameter. 11. Measuring diameter. 12. Extensometer drillholes. 13. Dial gauge extensometer. 14. Steel rod. 15. Expansion wedges. 16. Excavation radius. 17. Measuring radius. 18. Inscribed circle for flat jacks. 19. Rockbolt or extensometer anchor. 20. Reaction frame ring.

The example shown here is the Austrian method and, while outdated, shows most of the essential components of the more common setups.

FIG. 2 Longitudinal, Cross-section, and Close-up View of the Radial Jacking Test Setup (2)

D6026 Practice for Using Significant Digits and Data Records in Geotechnical Data

D6032 Test Method for Determining Rock Quality Designation (RQD) of Rock Core

E122 Practice for Calculating Sample Size to Estimate, With Specified Precision, the Average for a Characteristic of a Lot or Process

3. Terminology

3.1 Definitions:

3.1.1 For definitions of common technical terms in this standard, refer to Terminology **D653**.

3.2 Definitions of Terms Specific to This Standard:

3.2.1 *deformation, n—in rock mechanics*, the change in the diameter of the excavation in rock (test chamber).

3.2.2 *measuring radius or diameter, n—in rock mechanics*, the distance from the center of the test chamber to extensometer anchor in question

4. Summary of Test Method

4.1 A circular test chamber is excavated in a location and orientation normal to the direction of interest. Exploratory holes are drilled perpendicular to the excavated chamber to map the geology, obtain rock core samples, and use as extensometer holes for the test.

4.2 Multiple point extensometers are placed in the drill holes with downhole anchors placed at specific locations determined from the drill hole data. The reaction frame is erected, and flat jacks are placed around the periphery of the frame. The annular space between the test chamber wall and the reaction frame and flat jacks is filled with concrete and allowed to cure.

4.3 A uniformly distributed pressure is applied to the chamber surfaces by flat jacks positioned around the reaction frame's circumference (Fig. 1, Fig. 2, and Appendix X1). Flat jack pressure is measured with a standard hydraulic transducer.